

CR2 FIRE DAMPER

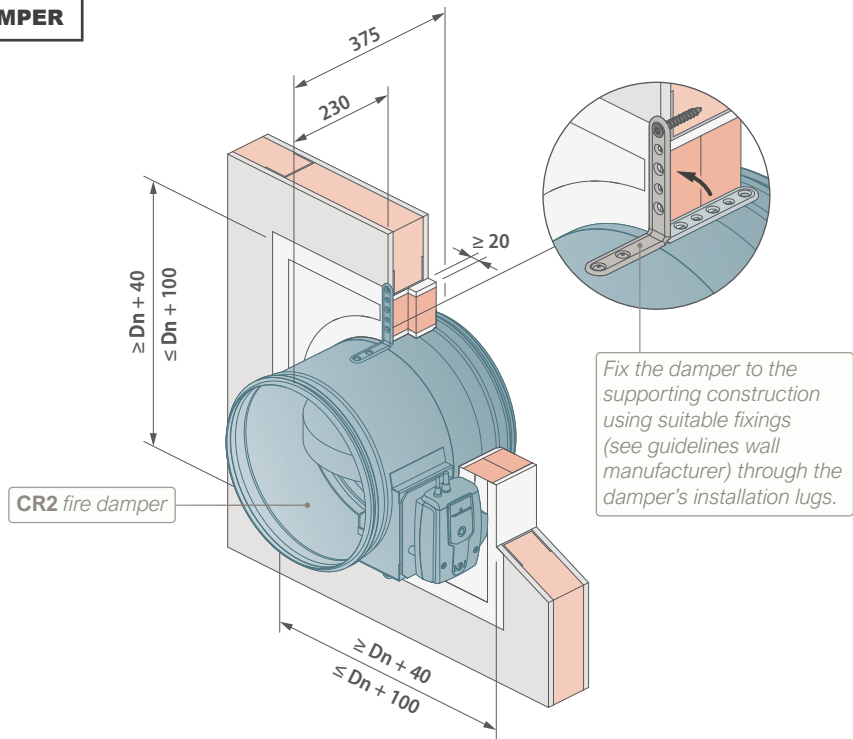

Fix the damper to the supporting construction using suitable fixings (see guidelines wall manufacturer) through the damper's installation lugs.

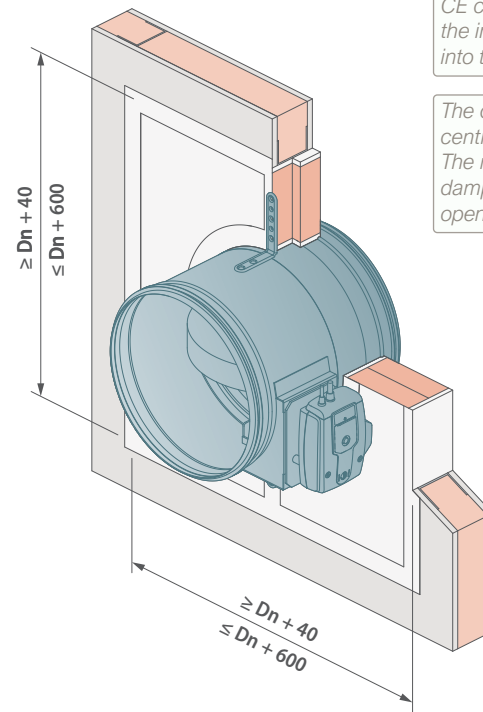

For larger wall openings (damper Dn + max. 600), CE certification is valid without the installation lugs being fixed into the supporting construction.

The damper doesn't need to be centred in the opening. The max. distance between the damper and the edge of the opening is 300 mm.

Supporting construction (slab or other) Stone wool ≥ 40 kg/m³ (optional)

Fire batt, 2 layers of 50 mm thick, ≥ 140 kg/m³. The joints of these 2 layers must be installed staggered (≥ 20 mm). For ex: Promat, Hilti.

Steel stud ≥ 50 mm, both C- and I-shaped studs allowed.

A max. of 2 fire dampers can be installed at tested minimal distances from each other. Apply 2 layers of fire batt as shown on this page, also between both dampers.

Fire batt sealant/coating to be applied on all cut edges and joints both sides of the penetration seal.

Till EI60S: 1x 12.5 mm gypsum boards type A both sides.
Till EI90S/E120S: 1x 15 mm gypsum boards type F both sides.

4-sided opening: the partition can support a deflection head without affecting the installation detail or classification of the fire damper.

Partition depicted has a thickness of 100 mm. Min. wall thickness allowed: 75 mm for EI60S or 80 mm for EI90S/E120S. If the wall thickness is < 100 mm, the fire batt is to be placed symmetrically in the partition and will protrude both sides.

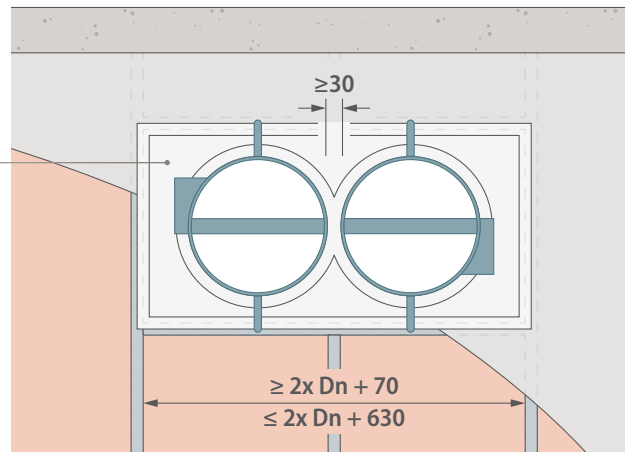

Provide appropriate break-away / flexible joint between fire damper and connecting ductwork on both sides of the assembly.

TECHNICAL FEATURES

- Damper range: ø200 till 630.
- Damper can be installed with blade in any position.

360°



- Damper can be installed with mechanism on either side of the wall (independent of fire side).
- Please consult with the fire batt manufacturer for appropriate sealant/coating
- A max. of 2 fire dampers can be installed at tested minimal distances from each other.

360°



≥ 30 mm



- To be read in conjunction with the CR2 Fire Damper Installation manual.
- Guidelines acc. to DW144/145 (not required for CE Certification):
 - Installation lugs as shown in the drawings are available upon request.
 - Provide appropriate break-away / flexible joint between fire damper and connecting ductwork on both sides of the assembly (DW145: Breakaway and flexible joints should incorporate materials, fixings, clamps, etc. that are manufactured from non-fire-resistant material with a low melting point such as aluminium, plastic etc.).
 - Provide space to access the internal components of a damper through an adjacent ductwork opening.
 - Supports to the connecting ductwork should be provided in accordance with the requirements of BESA Specification DW/144.
- Dimensions in mm unless otherwise stated.

INSTALLATION MANUAL



INSPECTION AND HANDOVER CHECK LIST



PLAN TITLE

CR2 fire damper in flexible supporting construction with a single layer of plasterboard. Installation detail with fire batt.

PAGE

1/1

CLASSIFICATION

EI90/E120 (ve i↔o)S



REV
B

DATE
15/06/2026

